

07-ON Chevy/GMC NEW BODY Shim Kit Special Instructions

IMPORTANT: Include Shim with Clamp-Clamp only where two layers of sheet metal are present. If box has DEALER installed GM Pickup Box Rail Protectors, refer to page 3 for Shim instructions with Box Rail Protectors.

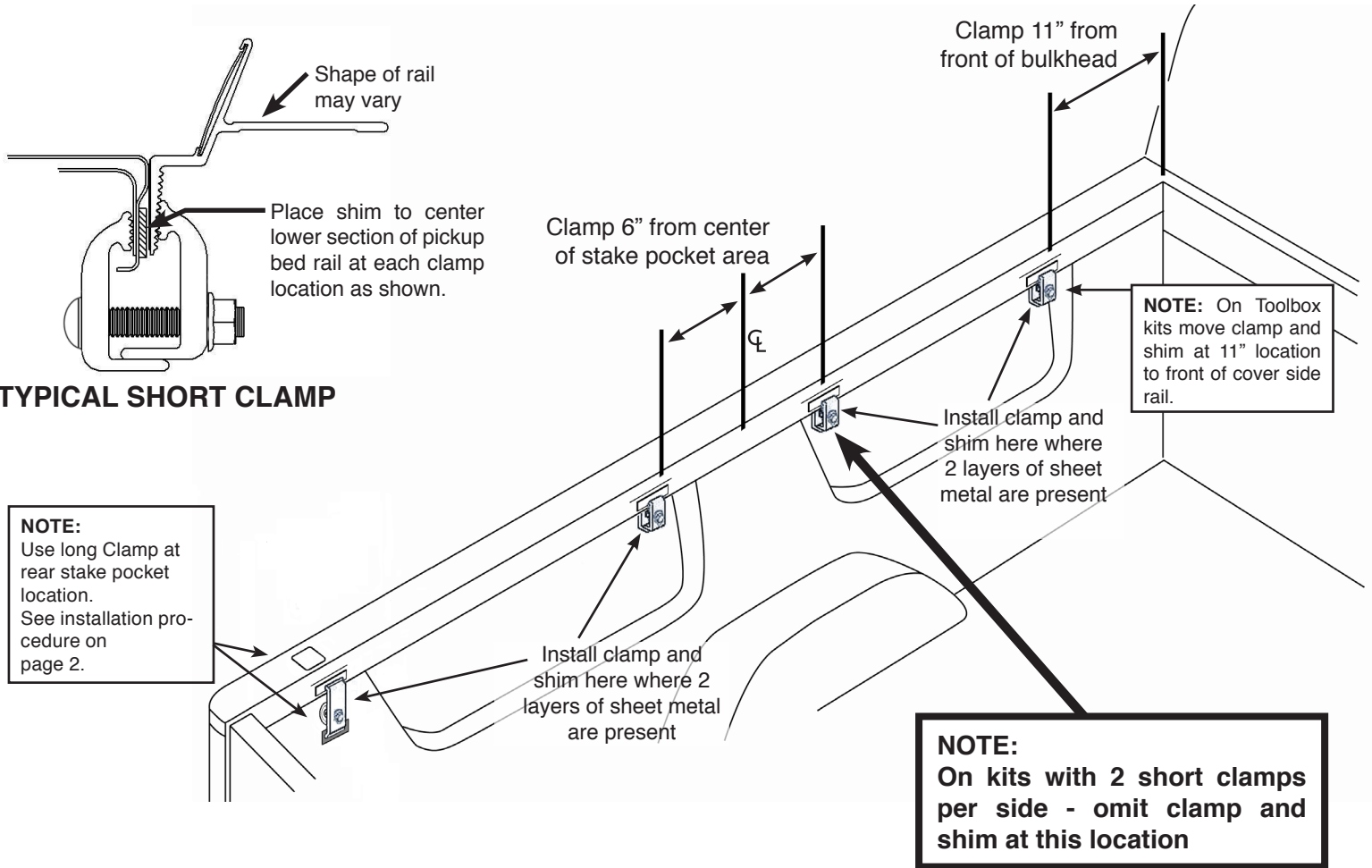

NOTE: IF BOX IS EQUIPPED WITH CARGO MANAGEMENT SYSTEM DO NOT REMOVE IT - SEE BELOW FOR CLAMPING TIP.

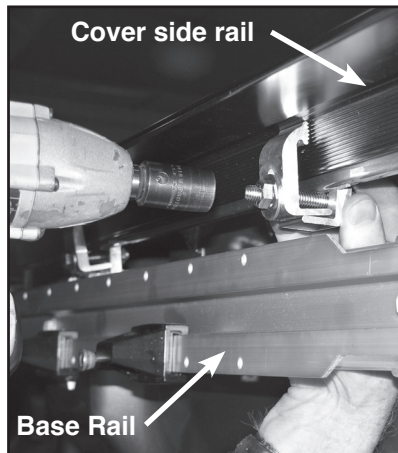

1. Do not disassemble clamp. Hold clamp as shown and reach up behind base rail. Then with clamp jaws open, tilt clamp and guide it to allow box lip to slip between clamp jaws.

2. Hold clamp up as shown. Make sure clamp is located where two layers of sheet metal are present and tighten. Locate each clamp as shown on diagram above, and tighten.

LONG CLAMP INSTALLATION

NOTE: IF BOX HAS DROP-IN LINER, CUT LINER TO CLEAR ROOM FOR CLAMP.



1. After short clamps are installed as shown on page 1, at rear of box under large hole in line with stake pocket, clean area and apply self adhesive protective strip.



2. At top of rear stake pocket, lower back half of long clamp with carriage bolt down into pocket.



3. Align and push bolt through hole on inside wall of box and hold there for next step.



4. Place other half of clamp over bolt and turn nut on finger tight.

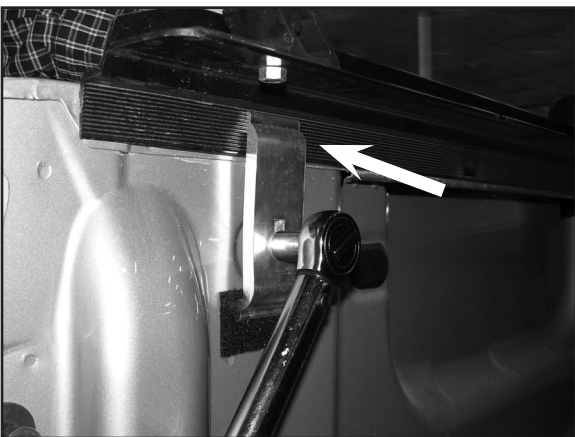

5. Adjust side rail height to clear tailgate as specified in owner's manual and hold it there. Push clamp up under side rail and tighten bolt. Torque this bolt to 18 ft. lbs. Repeat for opposite side.

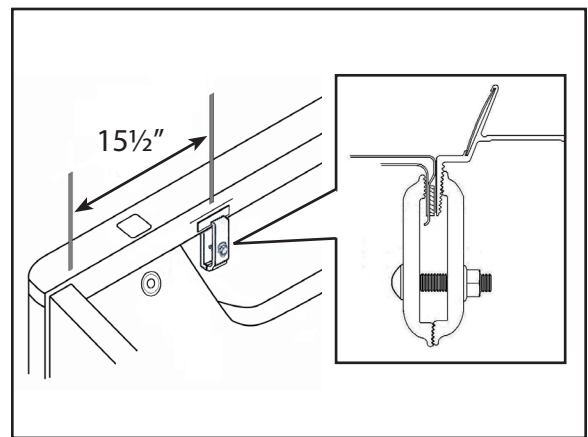

ALTERNATE LOCATION OF LONG CLAMP – only if stake pocket is not available. Even if stake pocket is utilized with an accessory, remove it and check for space. Usually the long clamp will install down in the pocket and still allow the accessory to be remounted.

TIP WHEN INSTALLING TONNO COVER ON BOX WITH GM PICKUP BOX RAIL PROTECTORS

NOTE: Below are examples of Dealer installed GM Pickup Box Rail Protectors. If installing a cover with these protective caps on, note location of shim's. Each shim should be adhered to **EXPOSED SIDE OF PROTECTOR CAP AS SHOWN BELOW** and **IN LINE WHERE TWO LAYERS OF SHEET METAL ARE PRESENT** AS SHOWN ON PAGE 1.

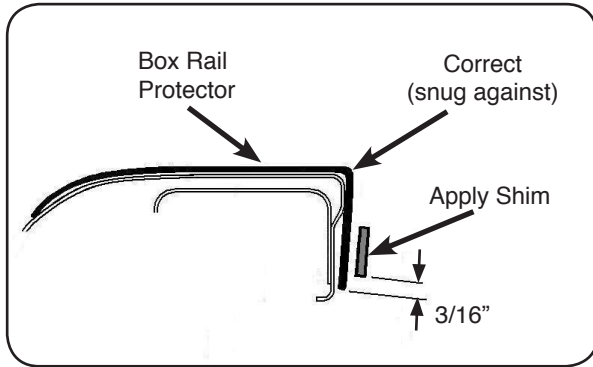

Dealer Correctly Installed Pickup Box Rail Protector

1. Note position of Rail Protector—snug against box. Adhere shims to **exposed side of protector** as shown above and in line where **two layers of sheet metal are present** as shown on page 1. Continue with these instructions and those in owner's manual.

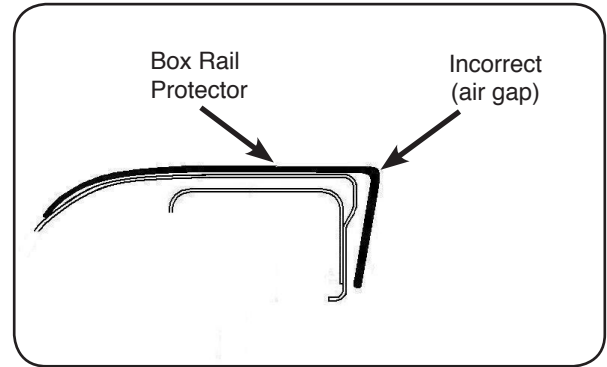

Dealer Incorrectly Installed Pickup Box Rail Protector

- TIP:** Even if box rail protectors have a gap as shown above, the cover rails can still be installed. Follow the same instructions as in 1 and 2. The pressure from tightened clamps will push box rail protector against the inside edge of box.

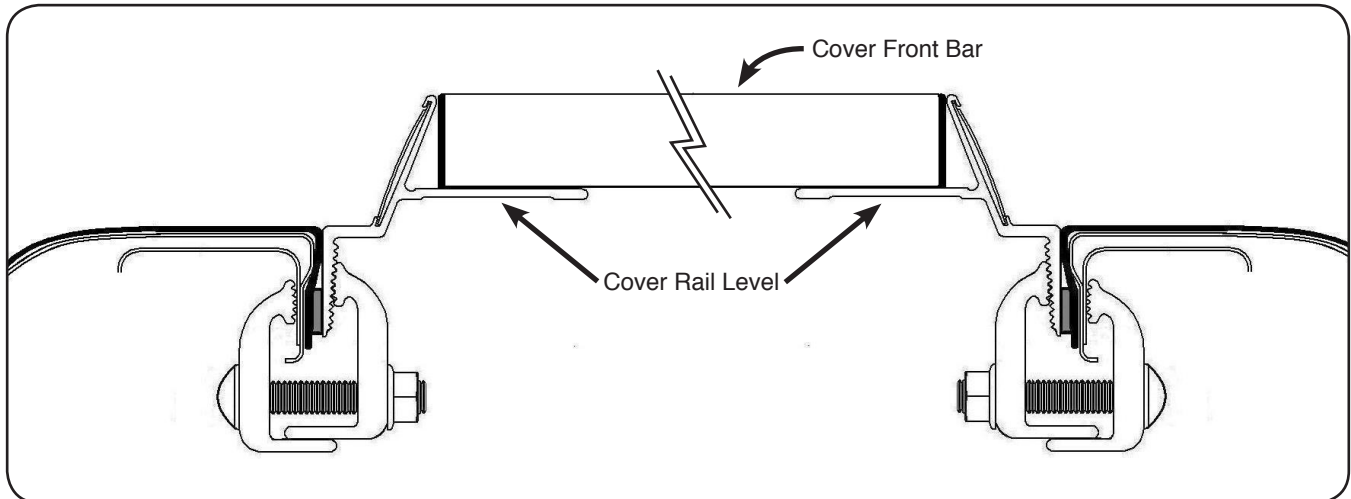

Shim, Cover Rail and Clamp Correctly Installed With Box Rail Protector

2. Correct position of shim, cover side rail, clamp and cover front bar. Shim on exposed side of protector. Cover rail in position against shim and protector. Clamp moved up high enough to hold cover rail level. Clamps tightened compress Dealer Installed GM Box Rail Protectors against inside edge of box. Cover's Front Bar will fit in between cover rails. In some cases, lifting up to rotate cover side rails slightly is all that is needed to make room for the front bar to fit in between the rails.