

Installation

PACBRAKE[®]
ENGINE & EXHAUST BRAKES



In-Line Mount **EXHAUST BRAKES**

VARIOUS AUTOMOTIVE APPLICATIONS INCLUDING:

Ford[®] trucks and Econoline vans equipped with Powerstroke, Dodge[®] Ram trucks equipped with Cummins Diesel and Navistar[®] vehicles without on board air, requiring an In-Line Pacbrake Exhaust Brake.

Getting Started

Thank you and congratulations on your purchase of a Pacbrake Inline Mount® exhaust brake kit.

Before starting, be sure you have attained the proper brake, mounting kit and control group for your vehicle. Below is a sample of all the parts needed for installation.

***Some models require back pressure adjustment. For these models a gauge kit is required. PN C10600.**

Verify the vehicles exhaust pipe size is correct for the adapters supplied.

NOTE: The adapters are expanded to slide over the existing exhaust pipe. Pacbrake adapters are available for all standard exhaust pipe sizes. Compare the exhaust pipe OD against the adapter I.D. before cutting the exhaust pipe.



- 1 With the exhaust brake on the bench, loosely attach the exhaust pipe adapters provided, and make a measurement to determine the length of vehicle exhaust pipe to be removed. The adapters are expanded to slide over the existing exhaust pipe—consider this in your measurement

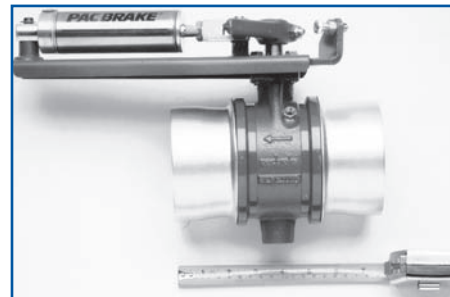

- 2 Select a location that has sufficient clearance for installation and servicing of the exhaust brake. This location should be as close to the turbocharger as possible and away from dirt and road spray. Keep in mind that Exhaust Brakes subjected to road spray will shorten the life and require a Remote Cylinder Breather Kit PN# C11020. Transfer the brake/adaptor measurement to this location and mark the exhaust pipe. Remove the exhaust pipe and cut the pre-marked section.

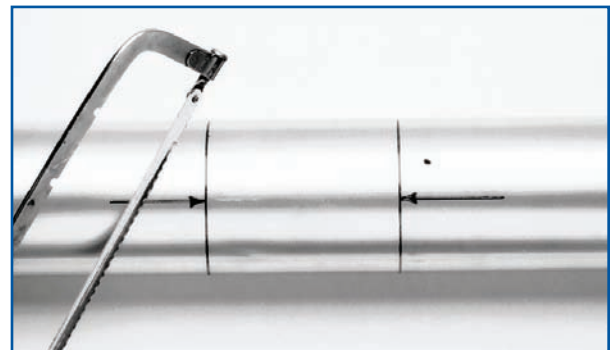

NOTE: In some cases, the cutting and welding of exhaust systems can be done without removing the pipe sections from the vehicle.

3 Clamp exhaust brake and exhaust system in place and tack weld prior to final welding. Weld the adapters to the sections of pipe, being careful to maintain the proper length and angles that exist. Welding can be done on the outside or the inside of the adapter, but it must be leak free.

NOTE: Clamped joints that exist between the brake and the engine must also be welded at this time to ensure the joint cannot separate or leak under pressure.

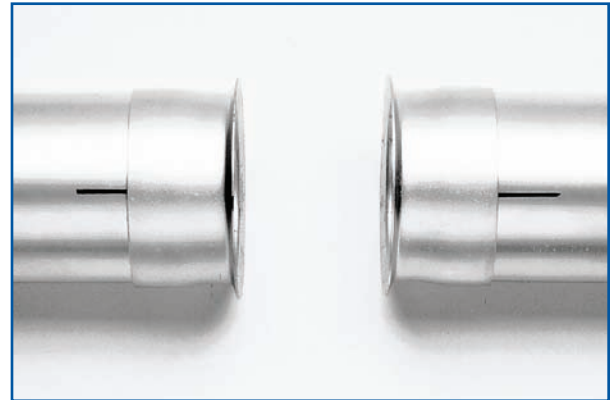

4 If removed, reinstall the front section of pipe on the engine. Torque turbo clamp to engine manufacturers specification. Center brake and tighten clamp on the exhaust brake pressure side. Install the rear section of pipe and loosely clamp. Check alignment of all sections and joints and torque “V” clamps to 15 FT.LBS.

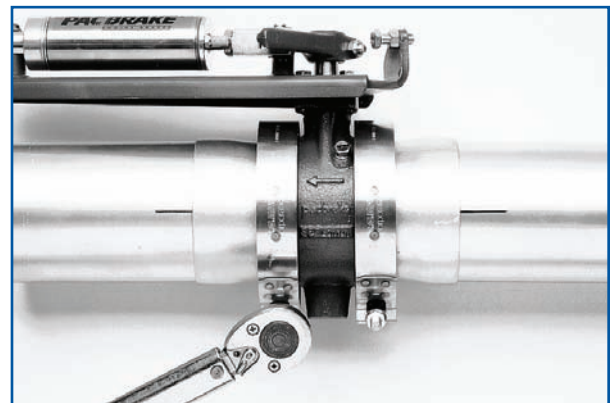

5 Select a location to mount the 12V compressor assembly. Mounting can be in any position. The location should be free of heat and contamination and must provide the compressor a good electrical ground by attaching the compressor grounding wire to a good ground source.

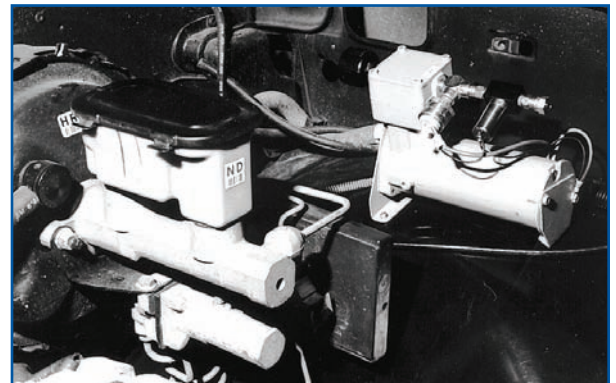

6 Prior to mounting the compressor, attach the air filter to the intake port and firmly tighten by hand. Attach the rubber mounting feet to the compressor mounting brackets using the grommets and grommet sleeves provided. These will isolate the compressor from vibration

NOTE: A remote breather kit for compressor intake air must be used if dust or road spray is present near the air intake filter. Pacbrake P/N C11620 is available and must be ordered separately. (shown in diagram)

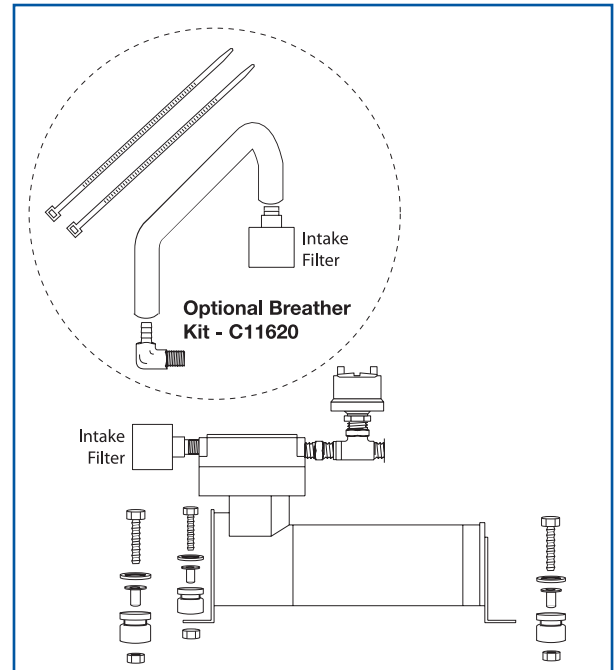

7 Route the Teflon air hose from the compressor assembly to the fitting on the air cylinder. Cut the hose and make the connection, being careful that the hose is secured away from any heat that could damage it.

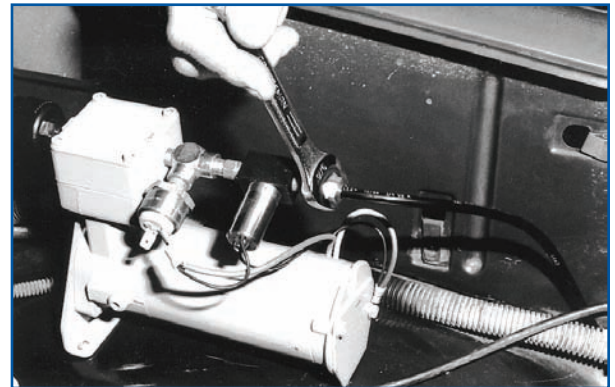

Wiring Schematic Index

- * 1998-2002 Ford Econoline Vans equipped with Powerstroke, see wiring schematic on page 6
- * Pre-1998 Ford Econoline Vans Equipped with Powerstroke, see wiring schematic on page 9
- * Navistar vehicles equipped with 444E, see wiring schematic on Page 13
- * 1999-2002 Dodge 24 Valve Electronic equipped with Cummins 5.9/ISB, see wiring schematic on page 14
- * Pre 1999 Dodge 12 Valve Mechanical equipped with Cummins 5.9, see wiring schematic on page 16

Application Guide

Engine	Max. Backpressure	@RPM	Exhaust Brake
Econoline or Ford Powerstroke	32 PSI	3400	C20366
Dodge Cummins 5.9L	35 PSI	3100	*C10300
Dodge Cummins 5.9L (with heavy duty valve springs)	60 PSI	3100	*C20369
Dodge Cummins 24 valve	60 PSI	3100	*C10300
International 444E	32PSI	3400	*C20366

*C10300 model is an adjustable brake and must be set during a road test using a backpressure gauge. Due to upgrades and variations between engines (i.e: different turbo chargers) it is not possible for Pacbrake to provide a preset brake to cover all possibilities.

Testing Exhaust Brake Back Pressure

Prepare for road test check or set exhaust brake back pressure. Pacbrake test gauge kit PT# C10600, can be purchased through the Pacbrake distribution system. This kit contains all the necessary parts to perform back pressure tests. The gauge used must be a dampened (liquid filled) type to accurately read this pressure.

1. Remove the 1/8" NPT plug located in the exhaust brake body and install fitting #3. Install the steel tube #4 into the fitting installed in the exhaust brake. Insert fittings #5 and #6 into the neoprene hose, moistening the fittings and firmly pushing the hose onto the barbed end. Install one end of the hose to the steel tube and the other to the gauge. Tighten all fittings securely. Route neoprene hose into cab.

Note: This test must be performed to ensure engine manufactures back pressure specifications are not exceeded - check the application guide for the correct maximum allowable PSI setting at governed speed.

2. Warm the engine to normal operating temperature.
3. Road test the vehicle by providing long durations of maximum RPM with the exhaust brake applied. This is best achieved with weight in the vehicle and a downhill grade.
4. Read and record the pressure achieved on the gauge at the governed engine speed. Pacbrake inline models have an adjustable stop bolt to adjust exhaust back pressure, This is done by the stop screw which limits the activating arm travel, thus reducing back pressure.

C10600 Test Gauge Kit

must be ordered separately

Illus.No.	Part No.	Description	Qty
1	C10650	Gauge	1
2	C10800	Hose	1
3	C10678	Fitting	1
4	C10677	Steel Tube	1
5	C10676	Fitting	1
6	C10775	Fitting	1

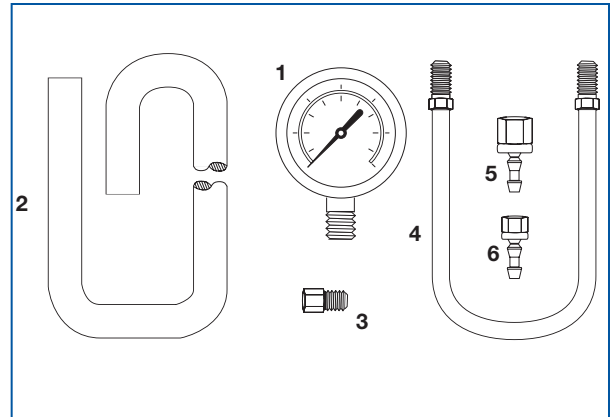

1998-2002 Ford Trucks and Econoline Vans with Powerstroke

- 1** For vehicles **WITHOUT** cruise control, omit steps 1 & 2. Remove the ground strap bolt on the driver-side of the firewall and install the relay receptacle and relay ground wire on this bolt. Install relay into the receptacle.



- 2** Ford installs a brake pressure applied switch on the front lower side of the master cylinder. Locate the black wire with a yellow stripe. Cut this wire and crimp on the two red terminals provided. Connect these to the mating terminals of the two remaining blue wires coming from the relay harness. Neatly secure all wiring with the plastic ties. Connect the wiring harness to the solenoid and to the cruise relay.

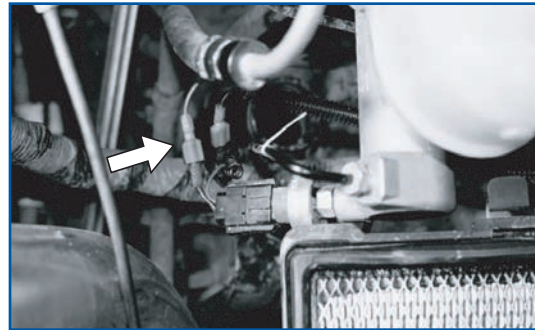

- 3** Remove the lower instrument panel (see arrow). Drill a 1/2" hole as shown for the dash switch. The dash switch location is a suggestion only. Install the Pacbrake on/off switch. Connect the two wiring harnesses to this switch, observing the correct wire and terminal locations as shown in the wiring schematic. Switch location can vary depending on customer choice or the availability of space. Choose a location which is convenient to the driver. Pacbrake offers a transmission gear lever mounted on/off switch for manual transmission equipped vehicles.



- 4** Locate a 12 volt ignition power source in the harness directly below the steering column (see arrow). Attach the yellow T-tap connector to this wire which should be 12V+ ignition switched.

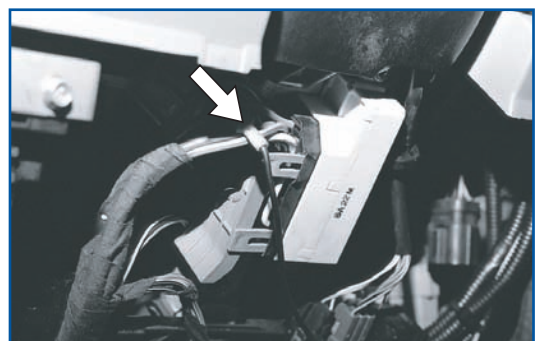

Pre 1998 Ford Trucks and Econoline Vans with Powerstroke

1 For vehicles without cruise control, omit steps 1 -2. Remove the relay and mount the receptacle of the C11971 harness to the firewall, including the green ground wire, with the screw supplied. Replace the relay. Connect both harnesses together using the remaining red wire.

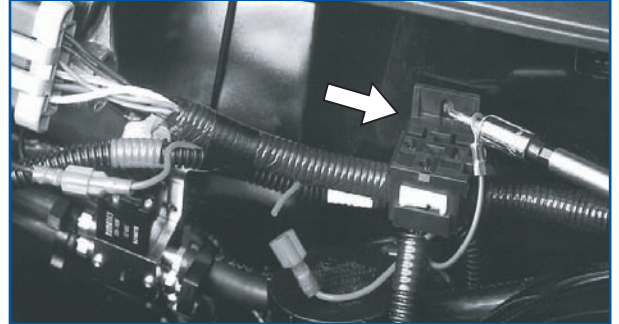

2 “Ford” installs a Brake Pressure Applied Switch on the TOP of their master cylinder. Open the convoluted conduit leading to this switch and pull out the black with yellow stripe wire. Cut this wire and crimp on the two red terminals supplied. Finally, connect these to the mating terminals of the two remaining blue wires coming from the relay. Replace the engine top cover and neatly secure all wiring with the plastic ties.



3 Drill a 1/2” hole through the firewall, above the throttle switch and below the clutch master cylinder or blanking plate (auto trans.). Feed the switch terminal end of the harness through this hole into the cab compartment.

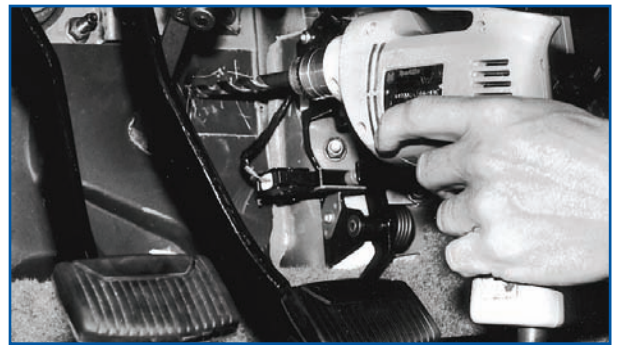

4 The Pacbrake throttle switch assembly mounts on the outside of the existing Ford switch located above the accelerator pedal, as shown in the schematic. Using a #20 Torx driver, remove the screw which attaches the existing switch and install the Pacbrake switch assembly. Align the two small bracket dimples with the depressions in the mounting bracket. Adjust the switch by bending the switch arm to obtain a “click” each time the throttle returns to idle. The Ford switch will also click at this time.

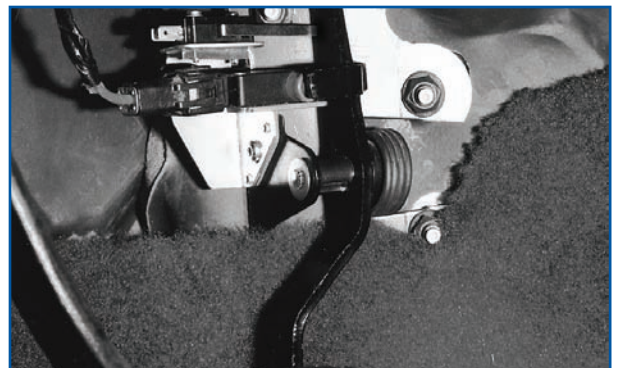

NOTE: Should the “locating” dimples not be realigned, poor throttle response will result.

Throttle Switch Schematic

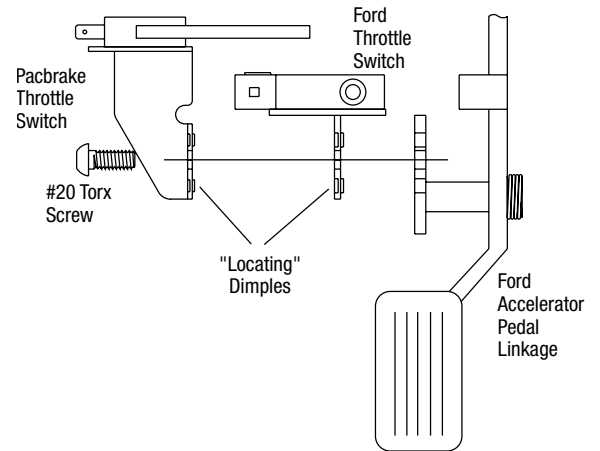

5

Locate a 12 volt ignition power source in the harness directly below the steering column (see pointer). Attach the blue “T-tap” connector to this wire which should be 12V+, ignition switched. Plug the black fused wire into this connector, attach fuse holder in an accessible location and replace panel. Continue the harness to the previously installed throttle switch, and connect the green and black wires to the terminal on the side of the switch and the one on the end adjacent to it. See schematic. Replace panel.



Check Operation

Start engine and turn Pacbrake on (engine will idle with Pacbrake engaged). Advance the throttle from idle to approximately 1200 RPM and back to idle several times, ensuring that the Pacbrake applies and releases each time.

Check for exhaust leaks at all connections. Shut engine down and do a final check of all clamps, fittings, wiring and plastic ties. Road test vehicle, and with cruise control activated, turn Pacbrake switch on. With throttle in idle position, cruise control should cancel immediately. NOTE: Whenever the Pacbrake switch is on and throttle at idle, cruise control cannot be engaged.

NOTE: Re-torque turbo clamp and exhaust brake clamps after 100 miles (engine should be cold).

Retarding Performance: 250 rhp @ 3,400 rpm. Dynamometer recorded @ the rear wheels (automatic transmission model only). If you have any questions or comments, please don't hesitate to give us call at 1-800-663-0096.

NAVPAC EXHAUST BRAKE WIRING SCHEMATIC

INTERNATIONAL 444E NAVPAK SYSTEMS

For vehicles: (WITHOUT) Allison WT Transmission (WITHOUT) ABS Braking (WITHOUT) On-board air supply

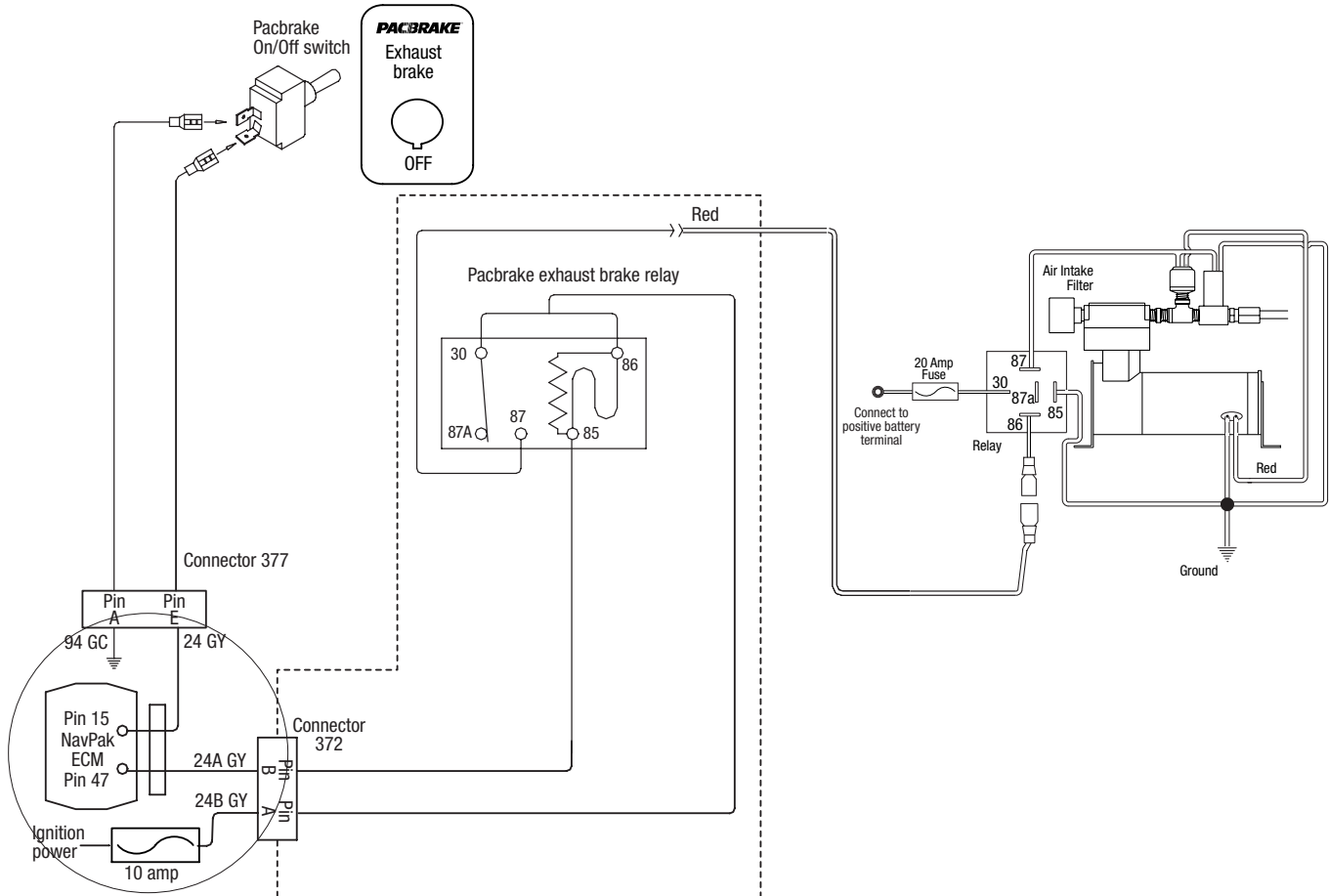

NOTE:

- Pacbrake wiring kit contains toggle type switch, source Navistar rocker switch part number 1677051-C1 if desired.
- The NavPak ECM requires exhaust brake circuit to be enabled by a Navistar Dealer.
- Relay shown is de-energized.
- Connector 372 located behind the left cylinder head. Remove protective cap and connect to Pacbrake harness (supplied).
- 8 Pin connector 377 located behind fuse panel.
- Information for this schematic was derived from vehicle systems at the date of this printing.
- Updates or variations by vehicle manufacturers constituting changes will not be the responsibility of Pacbrake.
- Pacbrake harness supplied in dotted area.
- Navistar installed wires in circled area.

EXHAUST BRAKE WIRING SCHEMATIC

1999 to 2002 DODGE 24 Valve Electronic Wiring Harness installation

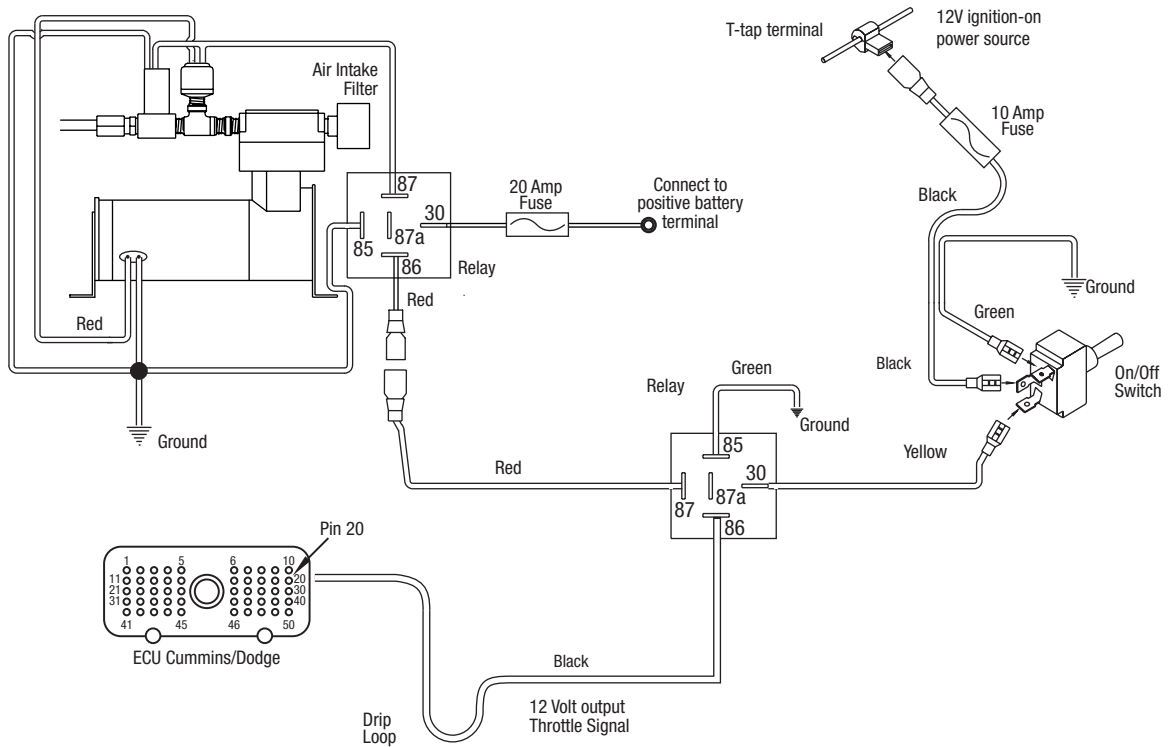

1

In a convenient location on the drivers side of the engine compartment, using the self tapping screw provided, mount the Pacbrake relay receptacle with the green ground terminal under the screw head. Install relay.

Route the loomed yellow wire through the firewall grommet into the cab to be connected to the dash switch later.

2

ECM CONNECTION

Disconnect both negative battery cables.

Remove the two cap-screws that attach the fuel filter head to the intake manifold, this should allow enough clearance to access the 50 pin connector.

Locate the 50 pin connector at the ECM shown above. Locate port #20 and remove the sealing plug. Be careful not to push the plug in.

Insert the black wire of the Pacbrake harness into pin #20 until it stops, then pull gently to ensure the terminal is locked in place.

Using the plastic ties supplied, secure the Pacbrake harness to the Dodge main harness. Be sure to follow Drip Loop in the Dodge harness when securing the Pacbrake harness.

Reinstall the fuel filter head to the intake manifold.

COMPRESSOR INSTALLATION

- 3** Select a location to mount the 12 volt compressor assembly. The location should be away from heat sources, contamination and must provide the compressor with a good electrical ground by attaching the compressor grounding wire to a good ground source. Route the compressor power supply to the positive battery terminal and connect, secure wire with tie-straps supplied.

NOTE: A remote breather kit for the compressor intake must be used if dust or road spray is present near the air intake filter. Pacbrake part# C11620 is available and must be ordered separately.

ON/OFF SWITCH INSTALLATION

Switch location can vary depending on customer choice or the availability of space. Choose a location which is convenient to the driver. Pacbrake offers a gear lever mounted switch for manual transmission equipped vehicles. (It is a good idea to consult the operator of the vehicle for their preference.) Most importantly, locate an area which is free from obstruction.

Remove dash panel below steering column.

Note the panel is double wall construction and the inner wall will require modification to accept the dash switch.

Drill a 1/2" hole, install the switch and wires as shown in the schematic for your application. Locate an ignition 12 volt positive source, attach the T-tap provided. Connect to black fused harness. Connect the yellow wire, routed into the cab earlier, to the dash switch. Attach the green wire to a good chassis ground. Reinstall lower dash panel.

EXHAUST BRAKE WIRING SCHEMATIC

Pre 1999 Dodge 12 Valve Mechanical

WIRING DIAGRAM

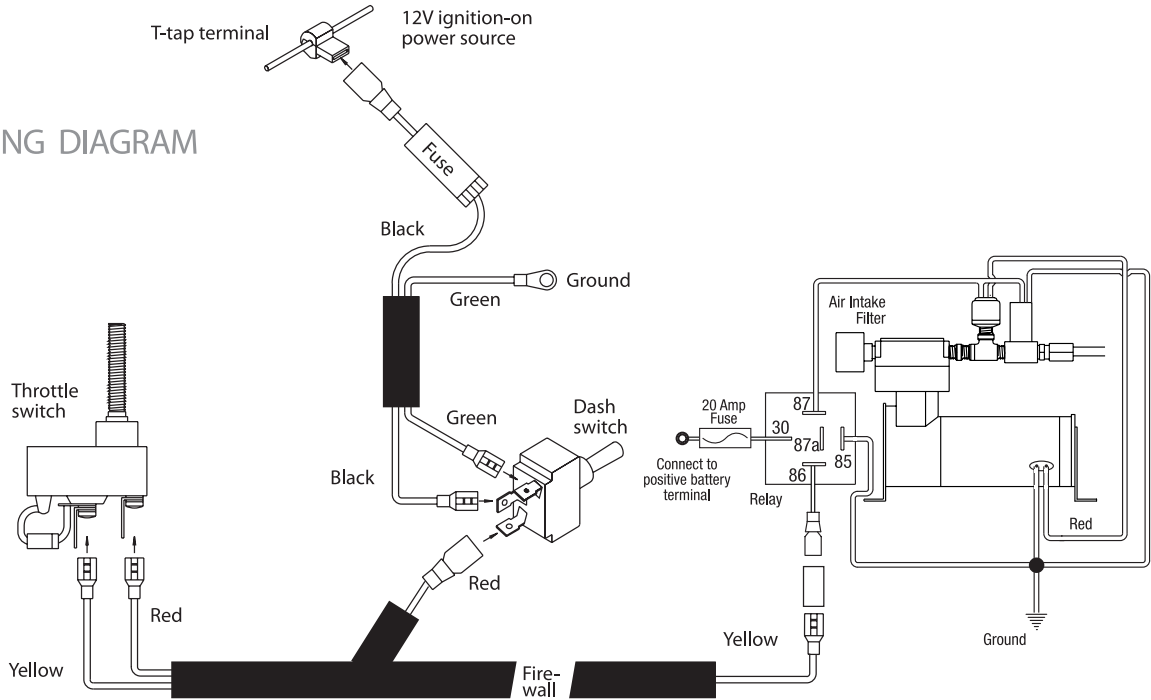

NOTE: Yellow wire must be attached to same terminal as the diode.

CAB WIRING

Switch location can vary depending on customer choice or the availability of space. Choose a location which is convenient to the driver. Pacbrake offers a gear lever mounted switch for manual transmission equipped vehicles. (It is a good idea to consult the operator of the vehicle for their preference.) Most importantly, locate an area which is free from obstruction. Remove lower dash panel for access.

At the base of the steering column locate ignition power supply.

1988 to 1993 models use medium blue 12 gauge wire, rear of the fuse panel.

1994 to 1997 models use medium blue 14 gauge

1998 models use black with orange trace

Install the "t-tap" connector on the power supply and attach the black wire from the fuse harness.

Route the fuse harness to the dash switch and connect the green wire to the top terminal, connect the black wire to the center terminal. Connect the red wire of the main harness to the lower terminal on the switch.

Route the main harness to the throttle switch and connect the yellow wire to the terminal with the diode and red wire to the other terminal.

Feed the loomed yellow wire through the boot beside the steering column into the engine compartment. Secure all wiring from moving parts using plastic ties provided. Reinstall the lower dash panel removed earlier.

ENGINE COMPARTMENT

Connect the yellow wire from the cab to the remaining relay wire using the splice connector supplied in the kit. Secure all wiring and hoses away from heat sources and moving parts.

THROTTLE SWITCH INSTALLATION 1988 to 1993

Remove dash panel below steering column to access fuse panel.

Locate stud shown in the photo and remove nut. The header pipe kit contains an alternate throttle switch bracket for pre-1994 vehicles.

Remove the switch from the bracket supplied in the main kit and install on the alternate bracket.

Install the throttle switch assembly with the switch arm horizontal. Reinstall the stud nut and tighten, making sure the switch arm is behind the accelerator lever.

Adjust the switch by loosening the screws and positioning it to “click” as the throttle returns to its released position. Cycle the throttle and listen for the click each time the throttle returns to idle. Tighten screws when adjustment is complete.

Connect wires as shown in schematic page 16.

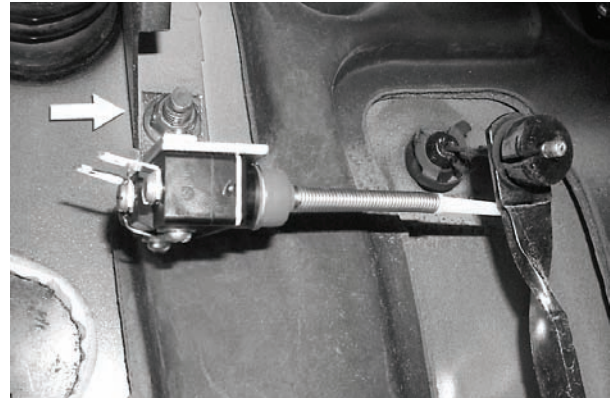

THROTTLE SWITCH INSTALLATION (1994 AND NEWER)

Remove dash panel below steering column. Locate the stud shown here and remove the nut.

Install the throttle switch assembly with the switch arm horizontal. Reinstall the stud nut and tighten, making sure the switch arm is behind the throttle lever.

Adjust the switch by loosening the screws and positioning it to “click” as the throttle returns to its released position.

Cycle the throttle and listen for the click sound each time the throttle returns to idle.

Connect wires as shown in schematic page 16.

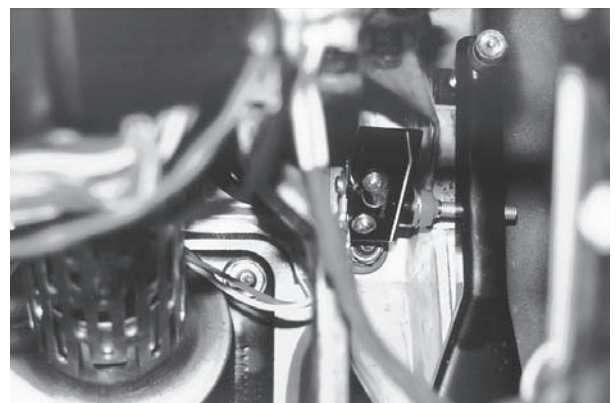

Pacbrake Company

toll-free: 800-663-0096

phone: 604-882-0183

fax: 604-882-9278

e-mail: info@pacbrake.com

Internet: www.pacbrake.com

Canada: 19594 96 Ave. Surrey BC V4N 4C3

USA: 250 H St. Box 1822 Blaine WA 98231-1822

Pacbrake exhaust brakes are protected by law.
U.S. patents 5,445,248. Patents pending. Pacbrake and Direct Mount are registered trademarks of Pacbrake Company. Other trademarks used herein are property of their respective holders.
Printed in Canada L2031.190505

PACBRAKE[®]
ENGINE & EXHAUST BRAKES