

FULLY AUTOMATIC CONTROL KIT

INSTALLATION INSTRUCTIONS

Congratulations on your purchase of a new Single Automatic Air Command Kit. This kit was designed to provide automatic height control of your vehicle.

Please take a few minutes to read through the instructions, identify the components, and learn how to properly install your Single Automatic Air Command Kit.

Be sure to take all applicable safety precautions during the installation of the kit. The illustrations in this manual all show the right, or passenger's side of the vehicle.

NOTE:

Prior to the installation of this kit, you must have installed the air helper spring kit designated for your vehicle. The Air Compressor Accessory Kit must also have been installed. See your air helper spring dealer for more information.

NOTE ON CONNECTING THE AIR LINE TUBING:

COMPRESSION FITTING

To connect the tubing to the fitting, first remove the nut and ferrule from the fitting. Slide the nut over the tubing, followed by the ferrule. If the fitting does not have a built-in tube support, insert one from your kit into the end of the tubing. Push the tubing as far as possible into the fitting and tighten the nut on

the fitting *see Figure "B"*. Fittings with brass ferrules should be finger-tight plus 3-1/2 turns. Fittings with nylon ferrules should be finger-tight plus 1-1/2 turns.

Should a leak be detected, do not over-tighten. Loosen the nut and make sure that the ferrule and sleeve are properly seated. Then re-install, making sure the tubing is pushed as far into the fitting as possible.

PUSH-TO-CONNECT FITTING

Your helper springs may have push-to-connect fittings. Cut the air line tubing as square as possible. To connect the air line tubing to the fitting, push the tubing into the fitting as far as possible *see Figure "C"*. If for any reason the tubing must be removed, first release the air pressure from the air system, then push the collar toward the body of the fitting and the tubing can easily be removed. To reassemble, make sure the tubing is cut square and push the tubing back into the fitting.

PARTS LIST

HEIGHT CONTROL VALVE	3599	1	LINKAGE PACK	1
AXLE BRACKET	5001	1	LINK SET	1
VALVE MOUNTING BRACKET	5004	1	#10 BOLT	2
FLEXIBLE TUBING	0938	1	#10 WASHER	2
HOSE CLAMP		1	#10 NUT	2
3/8" -16 FLANGED LOCK NUT	3022	2	1/4" x 1-1/4" BOLT	4
3/8" -16 x 3/4" HEX BOLT		2	1/4" FLAT WASHER	4
PUSH-TO-CONNECT T-FITTING		1	1/4" NUT	4

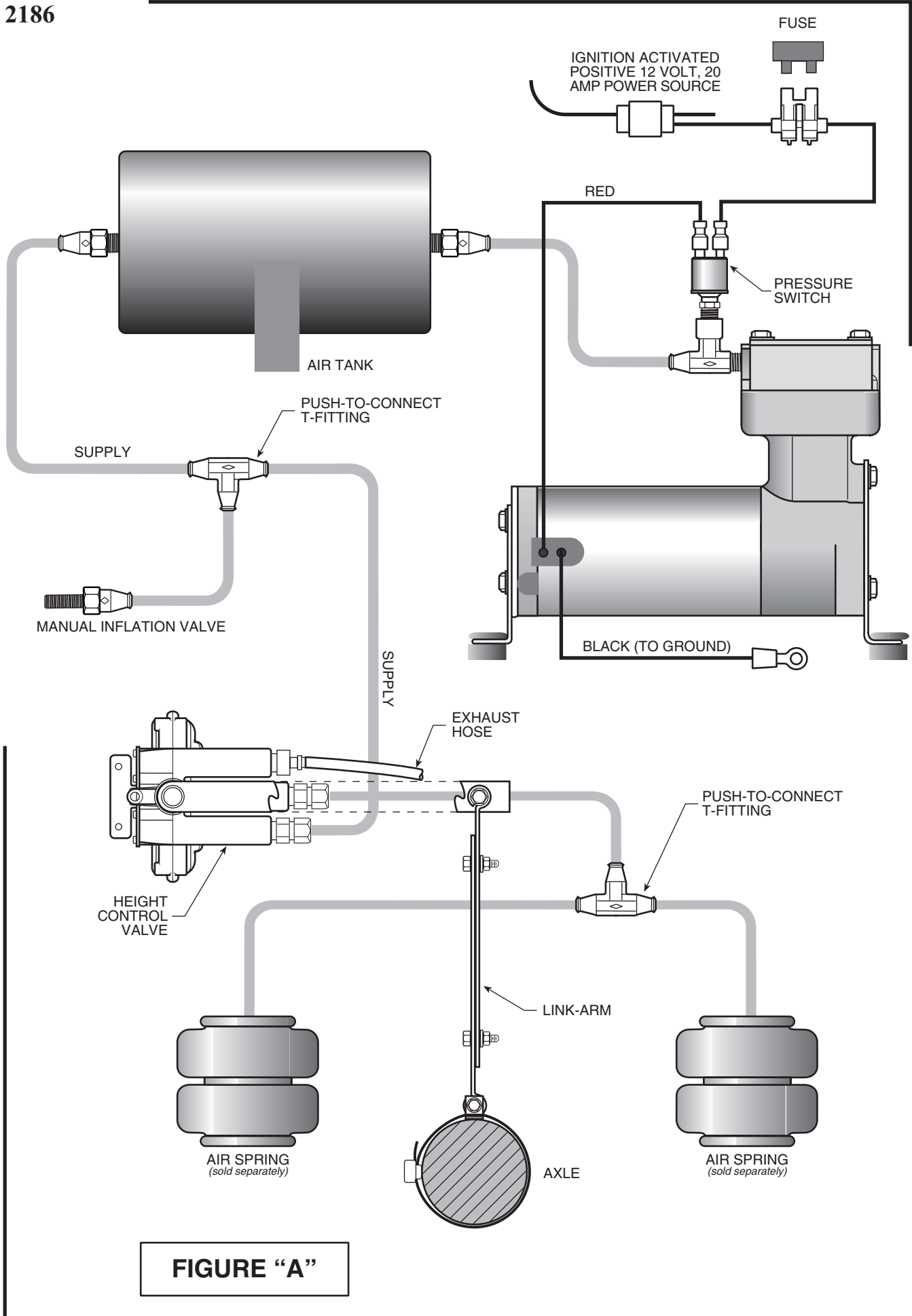
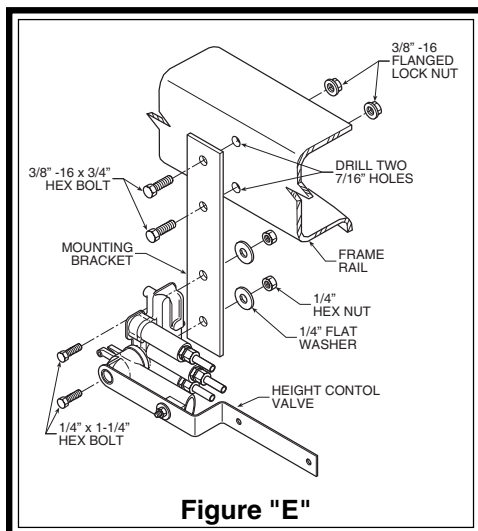
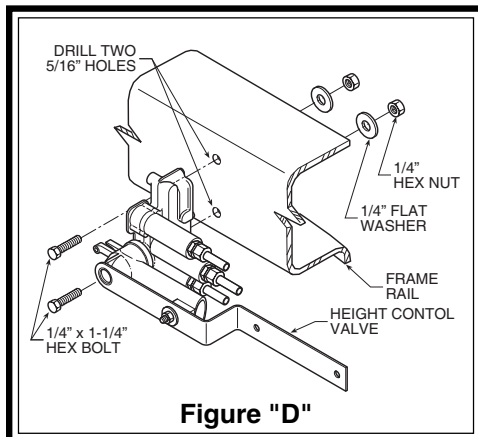
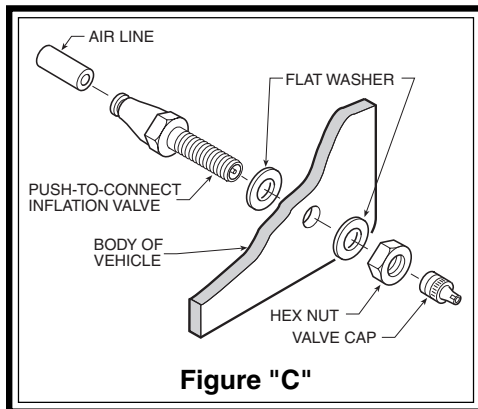
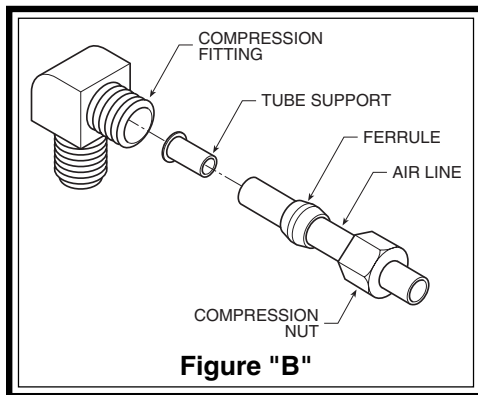

FIGURE "A"



STEP 1 - PREPARE THE AIR SYSTEM

The air tank and compressor kit should have been previously installed on the vehicle. Ensure that the air tank contains no pressure. Disconnect the compressor from the 12 volt power source and then remove the valve core from the external inflation valve or use a tire gauge to release air pressure from the system. *This installation assumes that there is no load in the vehicle.*

STEP 2 - SELECT A LOCATION FOR THE HEIGHT CONTROL VALVE

Review *Figure "A"* to become familiar with the installation of the height control valve. The height control valve should be mounted on the frame rail or other convenient location. The height control valve must be in a location that will allow the link-arm to reach the axle housing and be attached without any interference. The valve-arm on the height control valve must have enough clearance to operate freely and the link-arm should be oriented vertically.

STEP 3 - MOUNT THE HEIGHT CONTROL VALVE

Mount the height control valve in a location where it may be attached to the frame so that the arm extends over the axle. The valve must be in a location where the link-arm can reach from the valve arm to the axle housing. The height control valve can be attached directly to the frame rail above the axle or on a bracket attached to the frame rail. To attach the height control valve directly to the frame, use the mounting holes on the valve as a template to mark and drill two 5/16" holes. Use the 1/4" x 1-1/4" hex bolts, 1/4" washers, and 1/4" hex nuts to secure the valve to the frame *see Figure "D"*.

The height control valve can be attached to a bracket secured to the frame rail if the link-arm cannot span the distance between the valve arm and the axle housing *see Figure "E"*. Secure the mounting plate to the height control valve using the 1/4" x 1-1/4" hex bolts, 1/4" hex nuts, and 1/4" washers provided. Using the bracket as a template, mark and drill two 7/16" holes in the frame rail. Attach the bracket to the frame with the provided 3/8" x 3/4" hex bolts and 3/8" flanged lock nuts.

STEP 4 - MOUNT THE ANGLE BRACKET

Place the angle bracket on the axle directly beneath the valve arm. This bracket does not have to be on top of the axle. Find a location free from obstructions, such as brake lines. Place the hose clamp around the axle and the angle bracket and tighten the clamp. Ensure that the hose clamp does not clamp over the brake line, as to avoid damage to the line *see Figure "F"*

STEP 5 - ATTACH THE LINK-ARM

Measure the distance from the angle bracket on the axle to the mounting hole on the arm on the height control valve. Ensure that the arm on the height control valve is aligned horizontally. Fasten the individual link-arms together so that they span the measured distance with the provided #10 hex bolts, #10 hex nuts, and #10 washers *see Figure "G"*. If the link-arms are too long, they can be cut to allow them to be fastened together.

Fasten the link-arm to the height control valve with a 1/4" x 1-1/4" hex bolt, two 1/4" washers, and a 1/4" hex nuts *see Figure "G"*. Follow the same procedure to attach the link-arm to the angle bracket on the axle. The link arm should be installed so that it is aligned as close to vertical as possible.

STEP 6 - ROUTE THE AIR LINE TUBING

Check to make sure that there is no air pressure in the air system *see Step 1*. Cut a length of air line tubing that will reach from the air tank to the height control valve. Cut the tubing as square as possible. Insert one end of the air line tubing into the fitting on the air tank. Route the tubing to avoid sharp edges and heat from the exhaust system. Secure the tubing to the vehicle with the nylon ties provided.

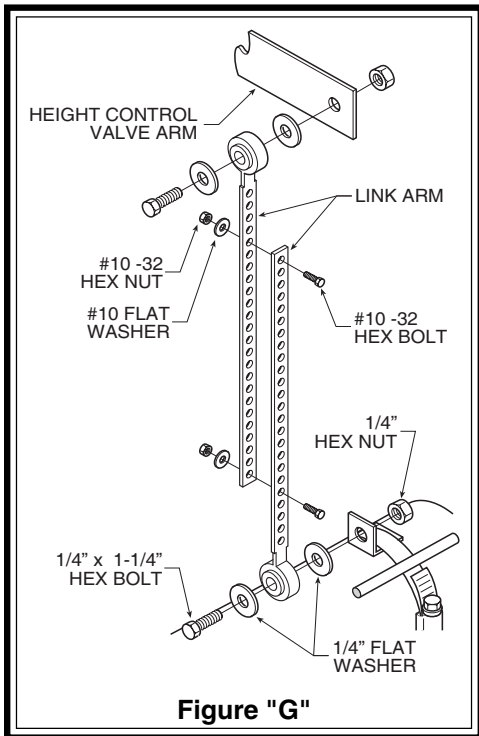
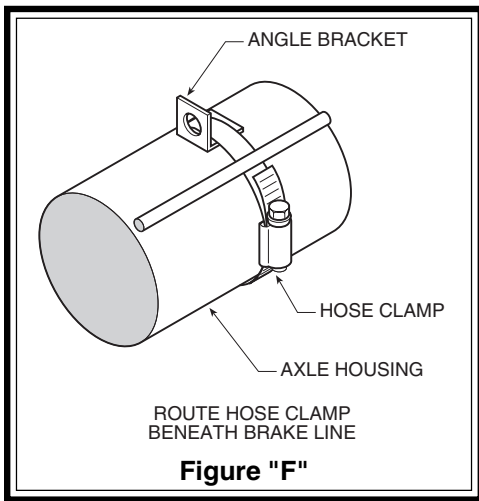

Install the other end of the tubing into the bottom port of the height control valve *see Figure "A"*. Secure the tubing to the height control valve with the compression fitting *see Figure "B"*. Install a short length of tubing into the middle port on the height control valve. On the other end of the tubing, install a push-to-connect T-fitting.

If your vehicle has existing air helper springs, release any air pressure from the air springs by removing the valve core from the inflation valve or by using a tire gauge to release the air. Remove the tubing from the inflation valves. Cut two lengths of air line tubing that will reach from the T-fitting to each air helper spring. Route the air line tubing to avoid sharp edges and heat from the exhaust system. Secure the tubing to the vehicle with the provided nylon ties. Do not fold or kink the tubing, as it may buckle. Insert the end of the air line from the air spring into the T-fitting and insert the other end of the tubing into the air fitting on the air helper spring *see Figure "A"*.

If you are installing air helper springs on your vehicle with the Single Automatic Air Command Kit, do not install the air line as stated in the Air Helper Spring manual. Install the air line tubing into the fitting on the air spring, and then route the air line tubing to the T-fitting. The installation of the manual inflation valves will not be necessary, as stated in the air helper spring instruction manual.

Install the exhaust fitting and air line tubing into the top port on the height control valve *see Figure "A"*. The tubing should be approximately 6" in length. The tubing will allow the air spring to exhaust air when the load is removed from the vehicle.

TEST THE SYSTEM

Re-attach the power source to the compressor. The compressor will run for a short period of time to build pressure in the air tank and air springs. The pressure switch will automatically turn the compressor off once the system reaches 120 P.S.I. Check the fittings for leaks with an applied solution of soap and water. If a leak is detected at a tubing connection, check to make sure that the tube is cut as square as possible and is pushed completely into the fitting. The tubing can easily be removed from the fitting by first releasing the air pressure from the system, then by pushing the collar towards the body of the fitting and then pulling out the tube. If a leak is detected where the brass fitting screws into the spring, first release the air pressure, then remove the tubing, followed by screwing the brass fitting into the air spring one additional turn or until the leak stops. Reinstall the tubing and reinflate the air springs and check for leaks as noted above.

This now completes the installation. When the vehicle is loaded, the Single Automatic Air Command Kit will detect the reduction in ride height. The air tank and compressor will inflate your air helper springs until the proper ride height

is achieved. When the load is removed, the air springs will automatically be deflated to achieve normal ride height. If your vehicle does not achieve the desired ride height, the length of the link-arm may be increased or decreased.

Note that after a load has been placed on or removed from the vehicle there will be a delay of a few seconds before the Single Automatic Air Command Kit responds to the change in ride height.

Should the compressor fail for any reason, air can be introduced into the system using the manual inflation valve installed with the compressor kit *see Figure "A"*. Attach an air chuck to the manual inflation valve and the air system will operate using the air introduced into the system.